

Automatic Sliding Door HH115

Automatic sliding door operator HH115---Smooth running, Low noise. Good choice for main entrance.

AUTOMATIC SLIDING DOOR OPERATOR

DOORTEC HH115

△△△△△△



CE

passed CE certification

2 Million

Life cycle Approved by TUV



With 80W motor more power

36 MONTHS

36 months warranty

PRODUCT DETAILS

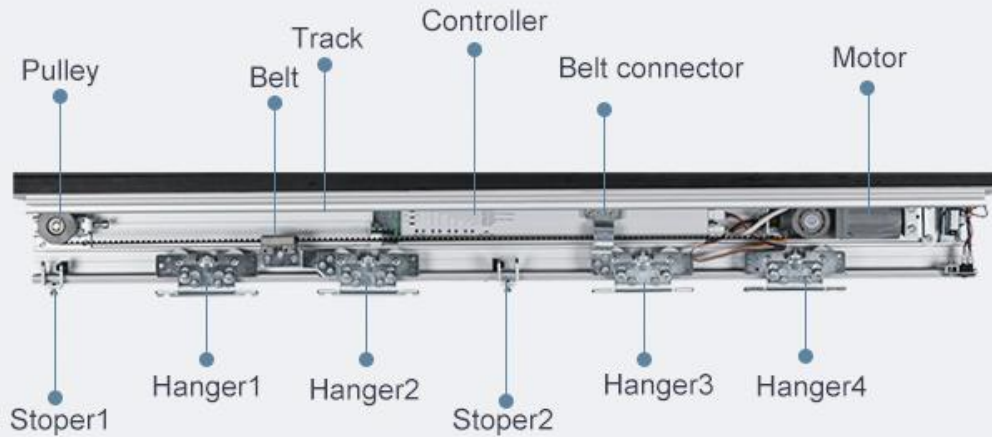

ABOUT MOTOR



80W Brushless Motor
Max Capacity **150kg**
Speed **2800**RPM/min

Low Noise
Less than 45dBA

* Test door weight 100kg
The sound of the motor starting up



ABOUT CONTROLLER

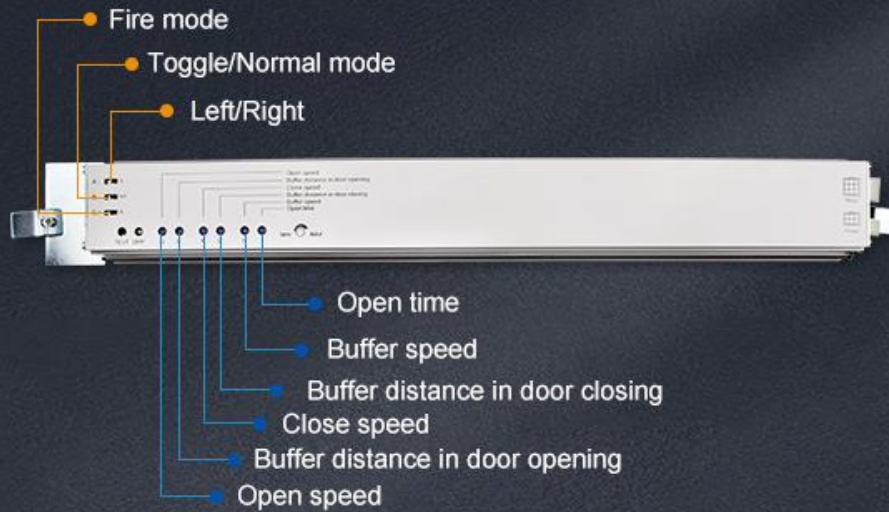

Program *Upgrade*

The New controller **status keeping function** after power off and restart

Upgrade

The old version of the controller will self-learn after power off and restart

Automatic Sliding Door HH115



Standard packaging is for Frame Foor

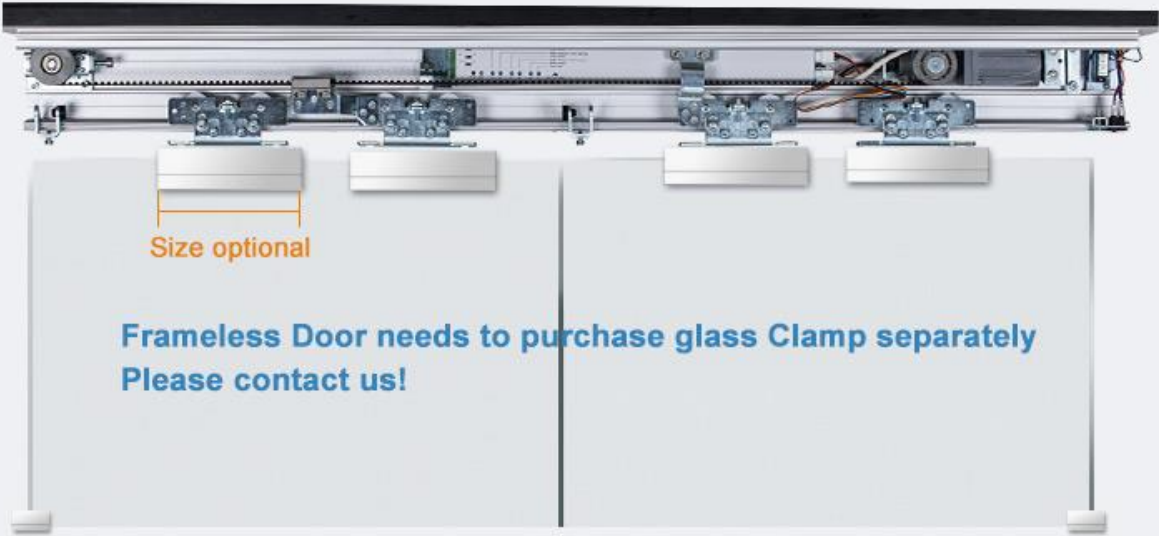

Size optional

**Frameless Door needs to purchase glass Clamp separately
Please contact us!**

STANDARD PACKING

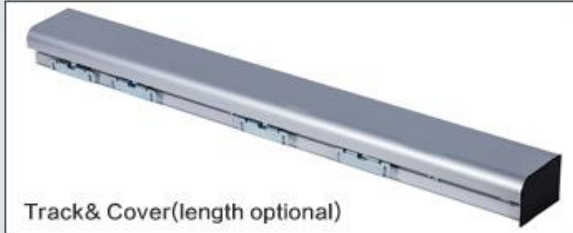

Track& Cover(length optional)



Controller



Power switch



Motor



Microwave Sensor



Photocell



Function remotes

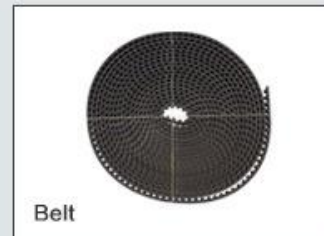

Belt



Pulley



Hangers (**New Anti-drop design**)



Stopper



Belt connector

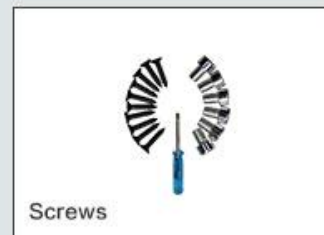

Screws

TECHNICAL DATA

Automatic Sliding Door HH115

HH115		
Door leaf mode	Single-opening	Double-opening
Door leaf weight	Max 150kg	Max 2*140kg
Door leaf width	DW=500-2000mm	DW=500-2000mm
Voltage	AC 90-240V 50-60Hz	
Opening speed	10-55cm/s (Adjustable)	
Closing speed	10-55cm/s (Adjustable)	
Opening time	0-20second (Adjustable)	
Manual open force	<40N	<50N
Motor	24V 80W 2800rpm	
Operating temperature	-10°C ~ +70°C	